

Data sheet diaphragm valve Type DIASTAR Six, Ten and Sixteen



GEORG FISCHER
PIPING SYSTEMS

1. Product features

- Actuators type Sixteen for 16 bar, Ten for 10 bar and Six for 6 bar nominal pressure
- No corrosion as there are no metal screws
- Increased leak-tightness at temperature changes due to identical temperature behavior of the materials used
- Due to the innovative design the flow rate could be doubled over all dimensions
- The valve body geometry results in a linear flow characteristic, clearly simplifying valve control
- 90° turnable air connection for a flexible installation
- The new design enables positioning of the weir rather close to the pipe wall. This produces a zero static branch valve that gives no chance to impurities and growth of bacteria

2. Materials

- Valve body:
 - PVC-U, PVC-C, ABS, PP-H, PP-n, PVDF, PVDF-HP
- Diaphragm:
 - EPDM, PTFE/EPDM, PTFE/FPM, FPM, NBR
- Housing: PP GF30
- Piston: PP GF30
- Sealings (piston and spindle): NBR
- Position indicator: PP
- Indicator cap: SAN
- Spindle: X14CrMoS17
- Springs: zinc coated steel
- Metal inserts – valve body: X6CrMoS17
- Metal inserts – air connection: 9SMnPb28k
- Metal inserts for accessory interface: CuZn39Pb3

3. Dimensions

d20 mm (DN15) ... d63 mm (DN50)

4. Types

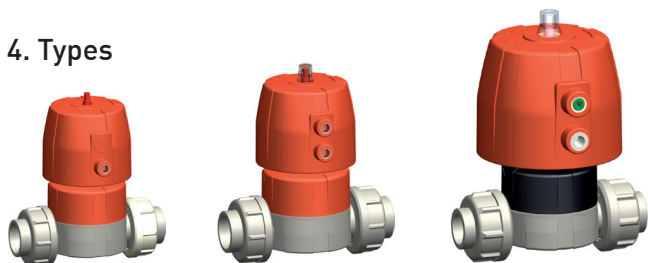

DIASTAR SIX

DIASTAR Ten

DIASTAR Sixteen

5. Pressure range

- PN16 for PVC-U as a configuration and for PVDF as standard
- PN10 for all other materials

6. Standards

ISO, BS, ASTM, ANSI and JIS

7. Cutaway model

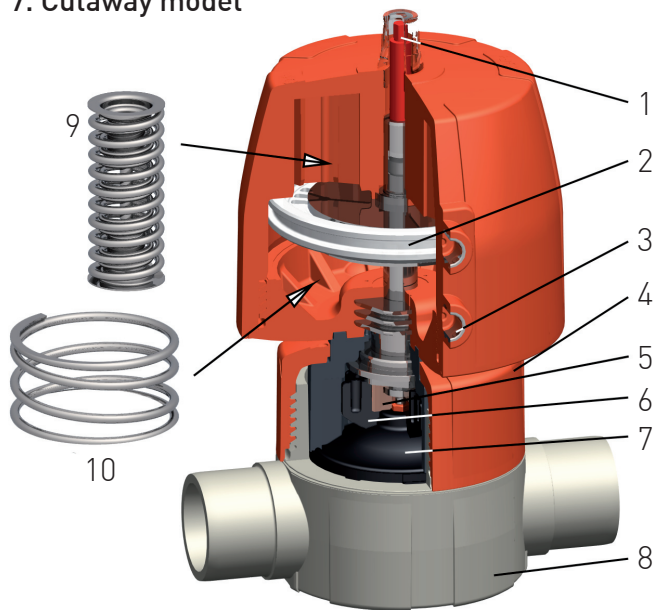

- 1 Optical position indicator with cap
- 2 Piston
- 3 Air connections
- 4 All-plastic housing
- 5 Diaphragm holder
- 6 Compressor
- 7 Diaphragm
- 8 Valve body
- 9 Pre-loaded spring sets for FC-mode (fail safe to close)
- 10 Spring for FO mode (fail safe to open)

Without spring = DA mode (double acting)

8. Indicator for diaphragm material

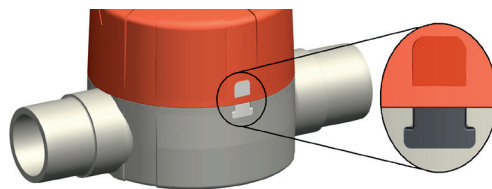

Friction lock on the valve body - colour shows type of diaphragm material:

- | | |
|-------|---------------------|
| black | EPDM diaphragm |
| white | PTFE/EPDM diaphragm |
| green | PTFE/FPM diaphragm |
| red | FPM diaphragm |
| blue | NBR diaphragm |

9. Valve bodies

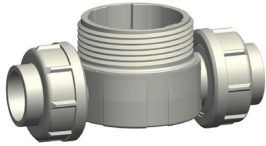

Type 514
True Union Design

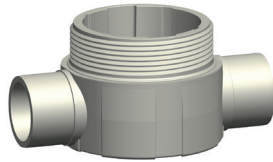

Type 515
Spigot ends

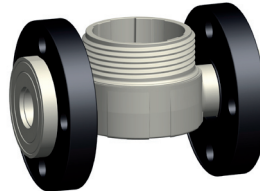

Type 517
Flanges

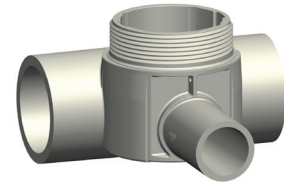

Type 519
Branched type

10. Pressure ranges

Types	Six FC			Ten DA/FO			Ten FC		
Valve body material	PVC-U, PVC-C, ABS, PP-H			PVC-U, PVC-C, ABS, PP-H, PP-n, PVDF, PVDF-HP			PVC-U, PVC-C, ABS, PP-H, PP-n, PVDF, PVDF-HP		
Diaphragm	EPDM	PTFE	control pressure max.	EPDM	PTFE	control pressure max.	EPDM	PTFE	control pressure max.
20DN15	6 bar	-	6 bar	10 bar	10 bar	5 bar	10 bar	10 bar	6 bar
25DN20	6 bar	-	6 bar	10 bar	10 bar	5 bar	10 bar	10 bar	6 bar
32DN25	6 bar	-	6 bar	10 bar	10 bar	5 bar	10 bar	10 bar	6 bar
40DN32	6 bar	-	6 bar	10 bar	10 bar	5 bar	10 bar	10 bar	6 bar
50DN40	6 bar	-	6 bar	10 bar	10 bar	5 bar	10 bar	10 bar	6 bar
63DN50	6 bar	-	6 bar	10 bar	10 bar	5 bar	10 bar	6 bar	6 bar
Working pressure	->	-		-><	-><		->	->	

Types	Sixteen DA/FO					
Valve body material	PVC-U, PVC-C, ABS, PP-H, PP-n, PVDF, PVDF-HP			PVC-U, PVDF, PVDF-HP		
Diaphragm	EPDM	PTFE	control pressure max.	EPDM	PTFE	control pressure max.
20DN15	10 bar	10 bar	5 bar	16 bar	16 bar	5 bar
25DN20	10 bar	10 bar	5 bar	16 bar	16 bar	5 bar
32DN25	10 bar	10 bar	5 bar	16 bar	16 bar	5 bar
40DN32	10 bar	10 bar	5 bar	16 bar	16 bar	5 bar
50DN40	10 bar	10 bar	5 bar	16 bar	16 bar	5 bar
63DN50	10 bar	10 bar	5 bar	16 bar	16 bar	5 / 6 bar
Working pressure	-><	-><		->	->	

Types	Sixteen FC					
Valve body material	PVC-U, PVC-C, ABS, PP-H, PP-n, PVDF, PVDF-HP			PVC-U, PVDF, PVDF-HP		
Diaphragm	EPDM	PTFE	control pressure max.	EPDM	PTFE	control pressure max.
20DN15	10 bar	10 bar	6 bar	16 bar	16 bar	6 bar
25DN20	10 bar	10 bar	6 bar	16 bar	16 bar	6 bar
32DN25	10 bar	10 bar	6 bar	16 bar	16 bar	6 bar
40DN32	10 bar	10 bar	6 bar	16 bar	16 bar	6 bar
50DN40	10 bar	10 bar	6 bar	16 bar	16 bar	6 bar
63DN50	10 bar	10 bar	6 bar	16 bar	10 bar	6 bar
working pressure	-><	-><		->	->	

Control pressure:

- FC mode: 6 bar
- DA/FO mode: 5 bar (DN50 Sixteen PTFE 6 bar)

11. Dimensions

Type 514

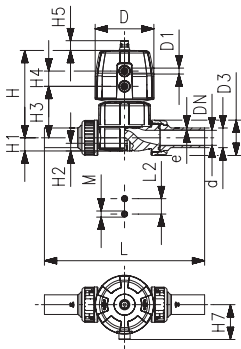

Type 515

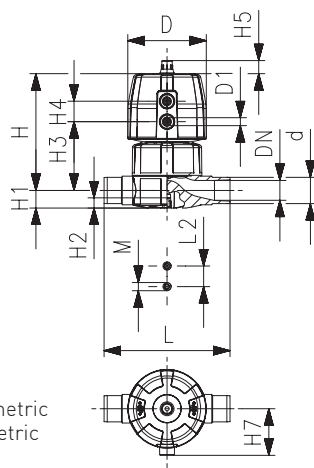

Type 517

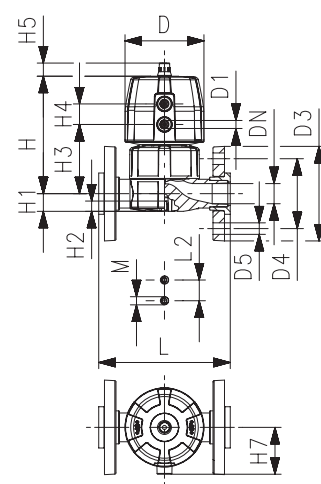

Type 519

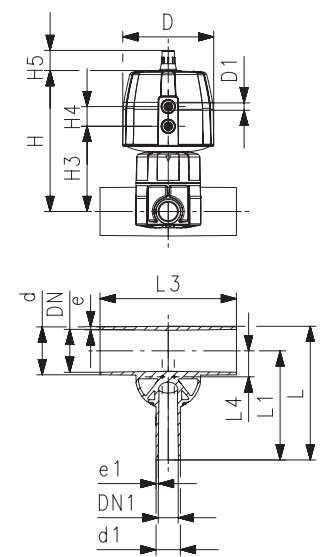

Legend

- L(1) Union with cemented socket, metric
- L(2) Union with threaded socket, metric
- L(3) Union with fusion socket
- L(4) Union with butt fusion spigot
- L(5) Union with butt fusion spigot (PVDF)
- L(6) Butt fusion spigot
- L(7) Cemented spigot, metric
- L(8) Socket fusion spigot
- L(9) Backing flange, metric

All data in millimeter [mm].

DIASTAR Six FC (Type 514 - 517)

d	DN	D	D1	D4	D5	L(1)	L(2)	L(3)	L(4)	L(5)	L(6)	L(7)
20	15	68	1/8"	65	14	128	128	128	224	196	124	124
25	20	96	1/8"	75	14	152	152	150	250	221	144	144
32	25	96	1/8"	85	14	166	166	162	262	234	154	154
40	32	120	1/8"	100	18	192	192	184	296	260	174	174
50	40	120	1/8"	110	18	222	222	210	328	284	194	194
63	50	120	1/8"	125	18	266	266	248	370	321	224	224

d	DN	L(8)	L(9)	L2	H	H1	H2	H3	H7	M	z	LE	Z for L(83)	Hx
20	15	124	130	25	101	14	12	60	43	M6	96	90	100	7
25	20	144	150	25	132	18	12	73	57	M6	114	108	118	10
32	25	154	160	25	143	22	12	84	57	M6	122	116	126	13
40	32	174	180	45	173	26	15	99	69	M8	140	134	144	14
50	40	194	200	45	193	32	15	119	69	M8	160	154	164	16
63	50	224	230	45	205	39	15	132	69	M8	190	184	194	16

DIASTAR Ten FC/FO/DA (Type 514 - 517)

d	DN	D	D1	D4	D5	L(1)	L(2)	L(3)	L(4)	L(5)	L(6)	L(7)	L(8)
20	15	68	1/8"	65	14	128	128	128	224	196	124	124	124
25	20	96	1/8"	75	14	152	152	150	250	221	144	144	144
32	25	96	1/8"	85	14	166	166	162	262	234	154	154	154
40	32	120	1/8"	100	18	192	192	184	296	260	174	174	174
50	40	150	1/4"	110	18	222	222	210	328	284	194	194	194
63	50	150	1/4"	125	18	266	266	248	370	321	224	224	224

d	DN	L(9)	L(2)	H	H1	H2	H3	H4	H5	H7	M	z	LE	Z for L(3)	Hx
20	15	130	25	101	14	12	60	24	16	43	M6	96	90	100	7
25	20	150	25	132	18	12	73	25	16	57	M6	114	108	118	10
32	25	160	25	143	22	12	84	25	16	57	M6	122	116	126	13
40	32	180	45	173	26	15	99	26	26	69	M8	140	134	144	15
50	40	200	45	214	32	15	119	36	26	88	M8	160	154	164	19
63	50	230	45	226	39	15	132	36	26	88	M8	190	184	194	23

DIASTAR Sixteen FC (Type 514 - 517)

d	DN	D	D1	D4	D5	L(1)	L(2)	L(3)	L(4)	L(5)	L(6)	L(7)	L(8)
20	15	96	1/8"	65	14	128	128	128	224	196	124	124	124
25	20	96	1/8"	75	14	152	152	150	250	221	144	144	144
32	25	120	1/8"	85	14	166	166	162	262	234	154	154	154
40	32	150	1/4"	100	18	192	192	184	296	260	174	174	174
50	40	180	1/4"	110	18	222	222	210	328	284	194	194	194
63	50	180	1/4"	125	18	266	266	248	370	321	224	224	224

d	DN	L(9)	L2	H	H1	H2	H3	H4	H5	H7	M	z	z for L(3)	Hx
20	15	130	25	127	14	12	68	25	16	57	M6	96	100	7
25	20	150	25	132	18	12	73	25	16	57	M6	114	118	10
32	25	160	25	167	22	12	93	26	26	69	M6	122	126	13
40	32	180	45	196	26	15	101	36	26	88	M8	140	144	15
50	40	200	45	239	32	15	124	37	26	103	M8	160	164	19
63	50	230	45	251	39	15	137	37	26	103	M8	190	194	23

DIASTAR Sixteen FC (Type 519)

d	d1	DN	DN1	DN2	D	D1	L(6)	L1	L3	L4	H	H3	H4	H5	Hx
20	20	15	15	15	96	1/8"	117	96	162	12	130	71	25	16	7
25	20	20	15	20	96	1/8"	133	108	162	16	131	72	25	16	10
25	25	20	20	20	96	1/8"	133	108	162	16	131	72	25	16	10
32	20	25	15	20	96	1/8"	142	120	162	19	135	76	25	16	10
32	25	25	20	20	96	1/8"	142	120	162	19	135	76	25	16	10
32	32	25	25	25	120	1/8"	145	120	160	19	167	93	26	26	13
40	20	32	15	25	120	1/8"	149	128	180	23	175	101	26	26	13
40	25	32	20	25	120	1/8"	149	128	180	23	175	101	26	26	13
40	32	32	25	25	120	1/8"	149	128	180	23	175	101	26	26	13
40	40	32	32	25	120	1/8"	174	153	180	23	175	101	26	26	13
50	20	40	15	20	96	1/8"	160	134	180	27	148	90	25	16	10
50	25	40	20	25	120	1/8"	160	134	180	28	180	106	26	26	13
50	32	40	25	25	120	1/8"	160	134	180	28	180	106	26	26	13
50	40	40	32	50	180	1/4"	209	169	209	33	249	135	37	26	23
50	50	40	40	50	180	1/4"	209	169	209	33	249	135	37	26	23
63	20	50	15	20	96	1/8"	177	144	180	33	155	96	25	16	10
63	25	50	20	25	120	1/8"	177	144	180	35	187	113	26	26	13
63	32	50	25	25	120	1/8"	177	144	180	35	187	113	26	26	13
63	40	50	32	50	180	1/4"	225	192	220	39	255	141	37	26	23
63	50	50	40	50	180	1/4"	225	192	220	39	255	141	37	26	23
63	63	50	50	50	180	1/4"	225	192	220	39	255	141	37	26	23
90	20	80	15	25	120	1/8"	205	159	190	47	200	126	26	26	13
90	25	80	20	25	120	1/8"	205	159	190	47	200	126	26	26	13
90	32	80	25	25	120	1/8"	205	159	190	47	200	126	26	26	13
90	50	80	40	50	180	1/4"	254	207	250	51	269	155	37	26	23
90	63	80	50	50	180	1/4"	254	207	250	51	269	155	37	26	23
110	20	100	15	25	120	1/8"	227	171	190	56	209	135	26	26	13
110	25	100	20	25	120	1/8"	227	171	190	56	209	135	26	26	13
110	32	100	25	25	120	1/8"	227	171	190	56	209	135	26	26	13
110	50	100	40	50	180	1/4"	276	219	250	60	279	165	37	26	23
110	63	100	50	50	180	1/4"	276	219	250	60	279	165	37	26	23

DIASTAR Ten FO / DA (Type 519)

d	d1	DN	DN1	DN2	D	D1	L(6)	L1	L3	L4	H	H3	H4	H5	Hx
20	20	15	15	15	68	1/8"	117	96	162	12	104	63	24	16	7
25	20	20	15	20	96	1/8"	133	108	162	16	131	73	25	16	10
25	25	20	20	20	96	1/8"	133	108	162	16	131	73	25	16	10
32	20	25	15	20	96	1/8"	142	120	162	19	135	76	25	16	10
32	25	25	20	20	96	1/8"	142	120	162	19	135	76	25	16	10
32	32	25	25	25	96	1/8"	145	120	160	19	143	84	25	16	13
40	20	32	15	25	96	1/8"	149	128	180	23	151	92	25	16	13
40	25	32	20	25	96	1/8"	149	128	180	23	151	92	25	16	13
40	32	32	25	25	96	1/8"	149	128	180	23	151	92	25	16	13
40	40	32	32	25	96	1/8"	174	153	180	23	151	92	25	16	13
50	20	40	15	20	96	1/8"	160	134	180	27	148	90	25	16	10
50	25	40	20	25	96	1/8"	160	134	180	28	156	97	25	16	13
50	32	40	25	25	96	1/8"	160	134	180	28	156	97	25	16	13
50	40	40	32	50	150	1/4"	209	169	209	33	224	129	36	26	23
50	50	40	40	50	150	1/4"	209	169	209	33	224	129	36	26	23
63	20	50	15	20	96	1/8"	177	144	180	33	155	96	25	16	10
63	25	50	20	25	96	1/8"	177	144	180	35	163	104	25	16	13
63	32	50	25	25	96	1/8"	177	144	180	35	163	104	25	16	13
63	40	50	32	50	150	1/4"	225	192	220	39	230	136	36	26	23
63	50	50	40	50	150	1/4"	225	192	220	39	230	136	36	26	23
63	63	50	50	50	150	1/4"	225	192	220	39	230	136	36	26	23
90	20	80	15	25	96	1/8"	205	159	190	47	176	117	25	16	13
90	25	80	20	25	96	1/8"	205	159	190	47	176	117	25	16	13
90	32	80	25	25	96	1/8"	205	159	190	47	176	117	25	16	13
90	50	80	40	50	150	1/4"	254	207	250	51	244	150	36	26	23
90	63	80	50	50	150	1/4"	254	207	250	51	244	150	36	26	23
110	20	100	15	25	96	1/8"	227	171	190	56	185	126	25	16	13
110	25	100	20	25	96	1/8"	227	171	190	56	185	126	25	16	13
110	32	100	25	25	96	1/8"	227	171	190	56	185	126	25	16	13
110	50	100	40	50	150	1/4"	276	219	250	60	254	160	36	26	23
110	63	100	50	50	150	1/4"	276	219	250	60	254	160	36	26	23

12. Pressure-Temperature Diagram

The following Pressure-Temperature Diagrams are based on a lifetime of 25 years with water or similar media.

ABS

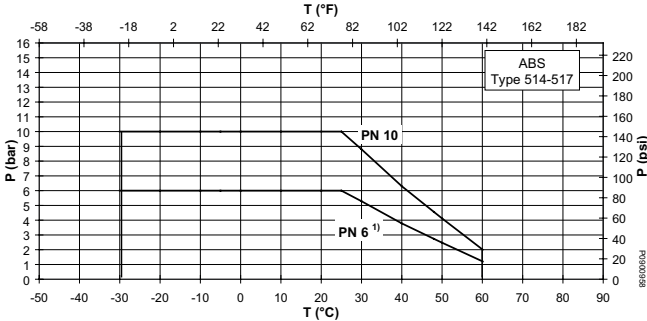

P Permissible pressure in bar, psi

T Temperature in °C, °F

1) Depending on the connection type and actuator, the nominal pressure is reduced to PN6

PVC-U

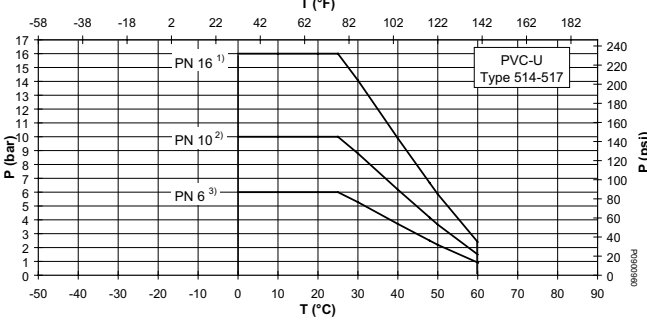

P Permissible pressure in bar, psi

T Temperature in °C, °F

1) Only with black PPS housing nut

2) Depending on the connection type and actuator, the nominal pressure is reduced to PN10

3) Depending on the connection type and actuator, the nominal pressure is reduced to PN6

PVC-C

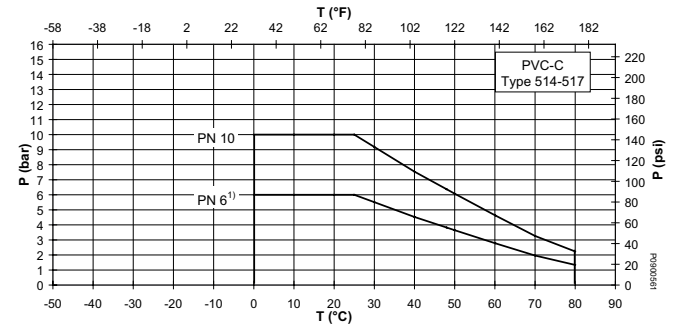

P Permissible pressure in bar, psi

T Temperature in °C, °F

1) Depending on the connection type and actuator, the nominal pressure is reduced to PN6

PP

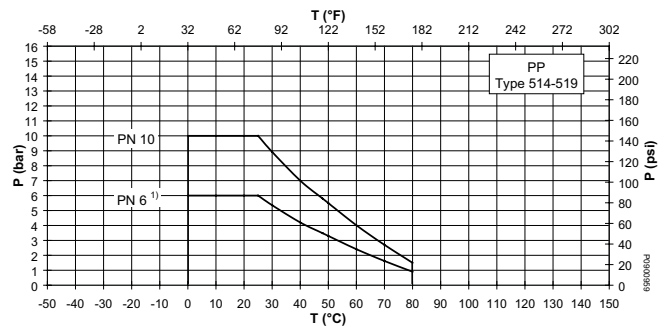

P Permissible pressure in bar, psi

T Temperature in °C, °F

1) Depending on the connection type and actuator, the nominal pressure is reduced to PN6

PVDF

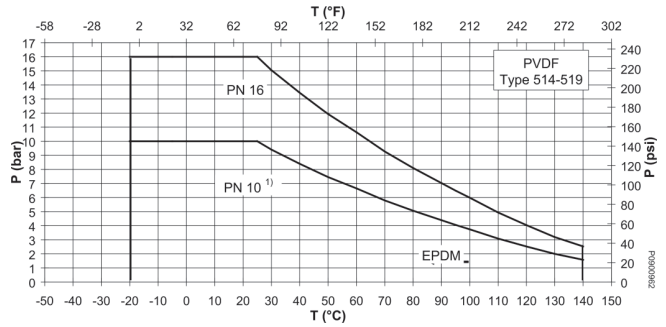

P Permissible pressure in bar, psi

T Temperature in °C, °F

1) Depending on the connection type and actuator, the nominal pressure is reduced to PN10

PN16 only with black PPS housing nut

13. Control pressure diagrams

The following diagrams show the control pressure depending on the nominal pressure PN.

DIASTAR SIX, FC with EPDM diaphragm

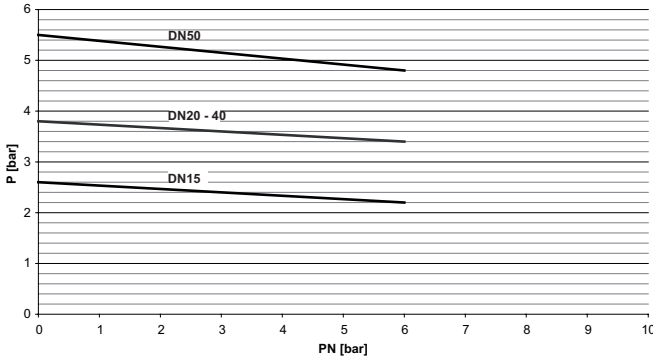

DIASTAR TEN, FC with EPDM diaphragm

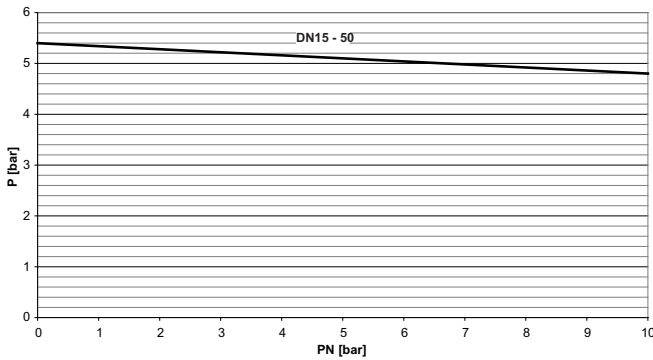

DIASTAR TEN, FC with PTFE diaphragm

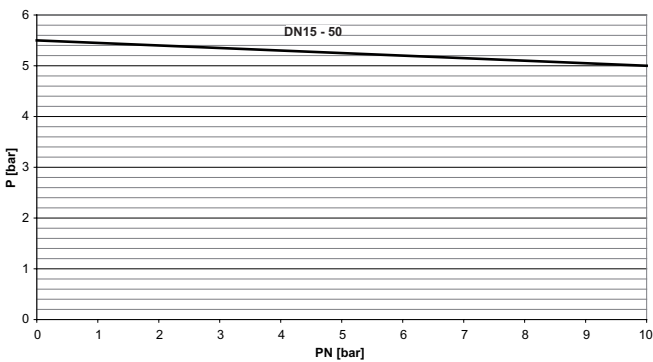

DIASTAR TEN, FO and DA with EPDM diaphragm

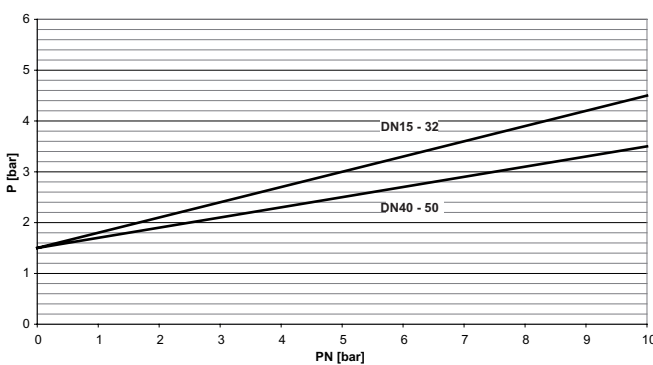

DIASTAR TEN, FO and DA with PTFE diaphragm

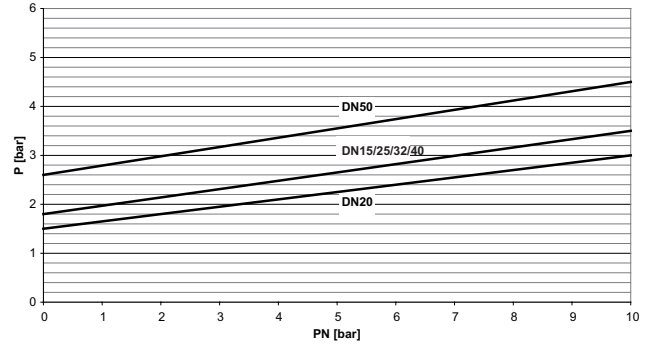

DIASTAR SIXTEEN, FC with EPDM diaphragm

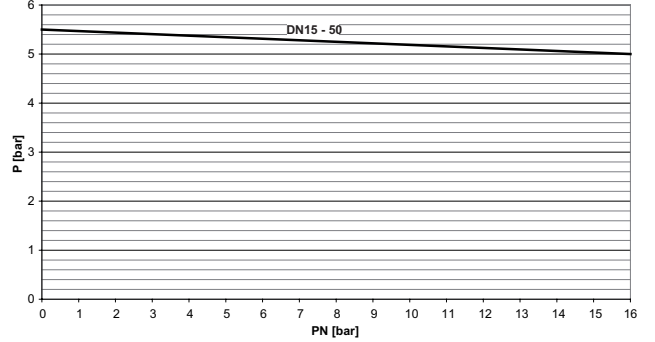

DIASTAR SIXTEEN, FC with PTFE diaphragm

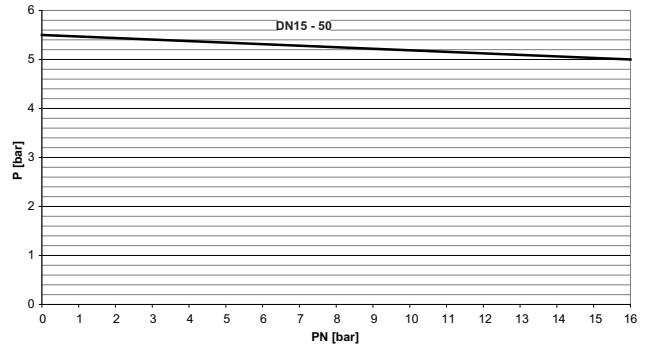

DIASTAR Sixteen, FO and DA with EPDM diaphragm

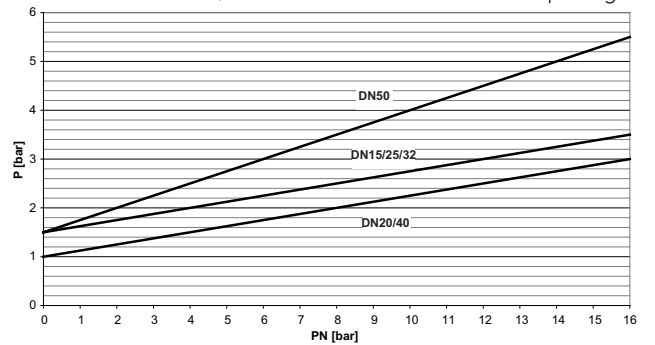

DIASTAR Sixteen, FO and DA with PTFE diaphragm

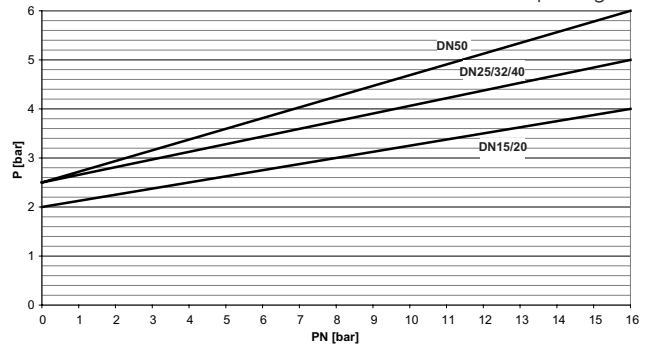

14. Flow characteristics

Type 514...517

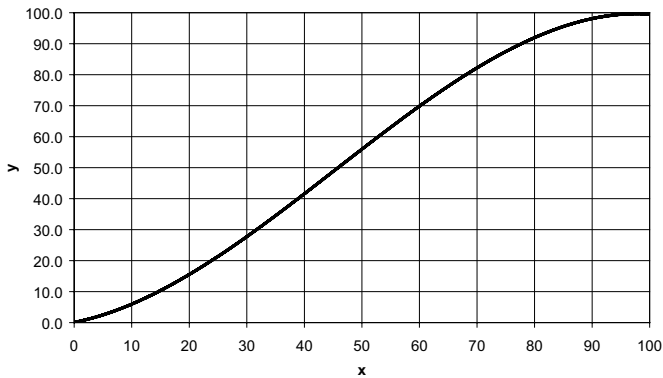

x Stroke in %
y kv, Cv value in %

Type 519

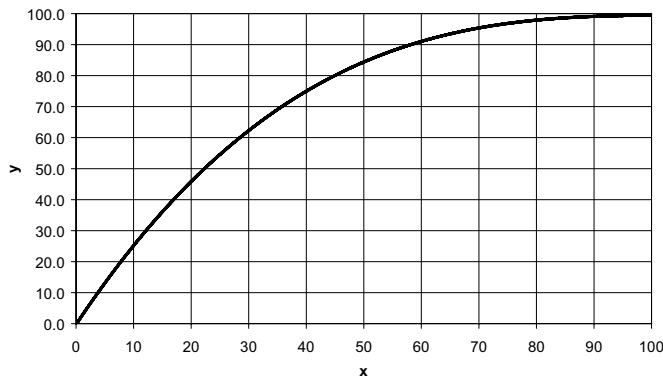

x Stroke in %
y kv, Cv value in %

15. Pressure loss

Type 514...517

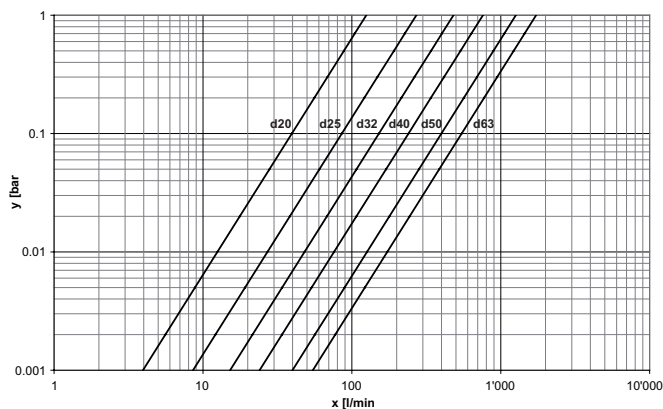

x Flow rate in l/min
y Pressure loss $\Delta p = 1 \text{ bar}$

16. kv 100 values

The kv values for each intermediate valve position can be determined by using the flow value characteristic and the kv 100 values.

Type 514 - 517

d [mm]	DN [mm]	kv[l/min] $\Delta p = 1 \text{ bar}$
20	15	125
25	20	271
32	25	481
40	32	759
50	40	1263 (960*)
63	50	1728 (1181*)

* DIASTAR Six

Type 519

d [mm]	d1 [mm]	DN [mm]	DN1 [mm]	kv[l/min] $\Delta p = 1 \text{ bar}$
20	20	15	15	57
25	20	20	15	89
25	25	20	20	118
32	20	25	15	80
32	25	25	20	105
32	32	25	25	231
40	20	32	15	85
40	25	32	20	119
40	32	32	25	153
40	40	32	32	187
50	20	40	15	86
50	25	40	20	160
50	32	40	25	206
50	40	40	32	524
50	50	40	40	667
63	20	50	15	84
63	25	50	20	150
63	32	50	25	184
63	40	50	32	471
63	50	50	40	610
63	63	50	50	747

17. Accessories

- Stroke limiter / Emergency manual override
- Feedback with limit switches AgNi, Au, Inductiv NPN or PNP
- Solenoid pilot valve
- Positioner
- Bus communication - AS Interface